

# Purifiers

Australia



## SEAGULL<sup>®</sup> IV

Drinking Water Systems

- Purifies\* water instantly
- No chemicals or electricity required
- Virtually maintenance free
- For use on mains, rain, river and ground water
- For Residential, Offices, Commerical, Hospitals, Schools Boats, Caravans and Motorhomes



drinking



cooking



ice-cubes

Seagull<sup>®</sup> IV  
X-1F Purifier



\*Independently certified to meet EPA Guide Standard Protocol for Microbiological Purifiers against bacteria, cysts and viruses!

## Here's how "Structured Matrix"™ technology purifies your water without using chemicals

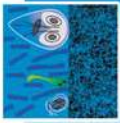

### ULTRAFINE MICROTRAINING

physically removes disease bacteria, pathogenic cysts like Giardia, Cryptosporidia, and other specific parasites and debris down to 0.1 microns (0.4 absolute). Removing pathogens also removes disease-causing toxins.

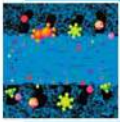

### BROAD SPECTRUM MOLECULAR CAPTURE

traps and captures specific organic and other chemicals such as pesticides, herbicides and solvents, as well as chlorine and other trace contaminants that can be toxic and/or carcinogenic, along with many foul tastes, odors, and color.

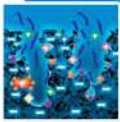

### ELECTROSTATIC REMOVAL

uses specially charged surfaces, essentially as chemical magnets, to remove minute particles, molecules and colloids suspended in the water.



These purification mechanisms all work together to naturally and ecologically remove contaminants from your drinking water. With "Structured Matrix" technology you don't have to drink chlorine or other pesticides to gain protection.



Seagull<sup>®</sup> IV X-1F  
p/n 701050

### Beauty and Durability

Seagull IV X-1F includes a pure water FP faucet and stainless steel ports for exceptional beauty as well as durability.

### Cartridge Wrap

All units include the RS-1SG purification cartridge with a pre-filter wrap for added protection.

### Easily Installed!

Top mounting pure water faucet and "Quick and Easy"™ pressure-proof installation lines eliminate the need to work in the dark recesses under your sink.

### Low Cost, Foolproof Operation!

Operates solely from your pressurized water system and requires no chemicals, post treatment storage tanks, waste-water lines or electricity.

### Dimensions: Seagull<sup>®</sup> IV X-1F

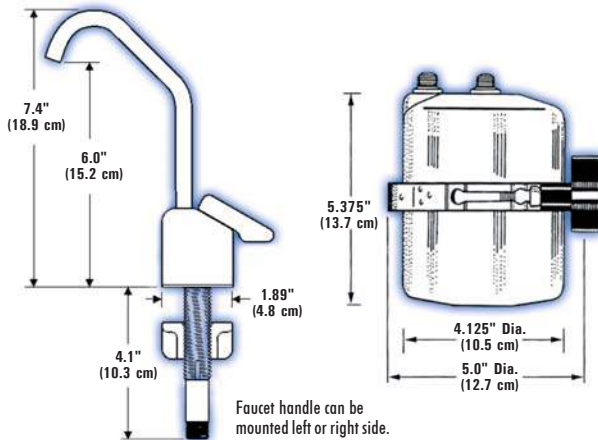

### Technical Specifications

Operating Temperature	33° F – 100° F (0.5° C – 38° C)**
Flow Rate	1.0 Gallon/min (3.8 Liters/min)
Cartridge Capacity*, Avg.	1000 Gallons (3800 Liters)
Operating Pressure	25 psi - 125 psi
Particle Retention - Micron	0.1 Nominal (0.4 Absolute)
Seagull <sup>®</sup> IV X-1F Purifier, chrome faucet	p/n 701050
RS-1SG Replacement Cartridge	p/n 788000

\*Capacities may vary depending on influent water quality. \*\*Intended for COLD WATER USE.  
Does not desalinate. • Patented in the U.S.A.  
EPA Est. Reg. No. 37403-PA-01

### Made in the USA By

General Ecology, Inc.

the pure science of safe water™



151 Sheree Blvd., Exton, Pennsylvania 19341-1292 USA

[www.generalecology.com](http://www.generalecology.com)

Distributed by:



Phone: 1300 303 605 or (08) 8431 4100

[www.purifiersaustralia.com.au](http://www.purifiersaustralia.com.au)

[Info@purifiersaustralia.com.au](mailto:Info@purifiersaustralia.com.au)

57 Kensington Rd, Norwood,  
South Australia, 5067